

# Service Schematics

# NOKIA 6270

## Introduction

### IMPORTANT:

This document is intended for use by authorized NOKIA service centers only.

“Service Schematics” was created with focus on customer care. The purpose of this document is to provide further technical repair information for NOKIA mobile phones on Level 3/4 service activities. It contains additional information such as e.g. “Component finder”, “Frequency band table” or “Antenna switch table”. The “Signal overview” page gives a good and fast overview about the most important signals and voltages on board. Saving process time and improving the repair quality is the aim of this document. It is to be used additionally to the service manual and other training or service information such as Service Bulletins.

All measurements were made using following equipment:

Nokia repair SW	: Phoenix version 2005.20.7.98
Oscilloscope	: Fluke PM 3380A/B
Spectrum Analyzer	: Advantest R3162 with an analog probe
RF-Generator / GSM Tester	: Rhode & Schwarz CMU 200
Multimeter	: Fluke 73 Series II

While every endeavour has been made to ensure the accuracy of this document, some errors may exist. If the reader finds any errors, NOKIA should be notified in writing.

Please send E-Mail to: [training.sace@nokia.com](mailto:training.sace@nokia.com)

### Copyright © NOKIA

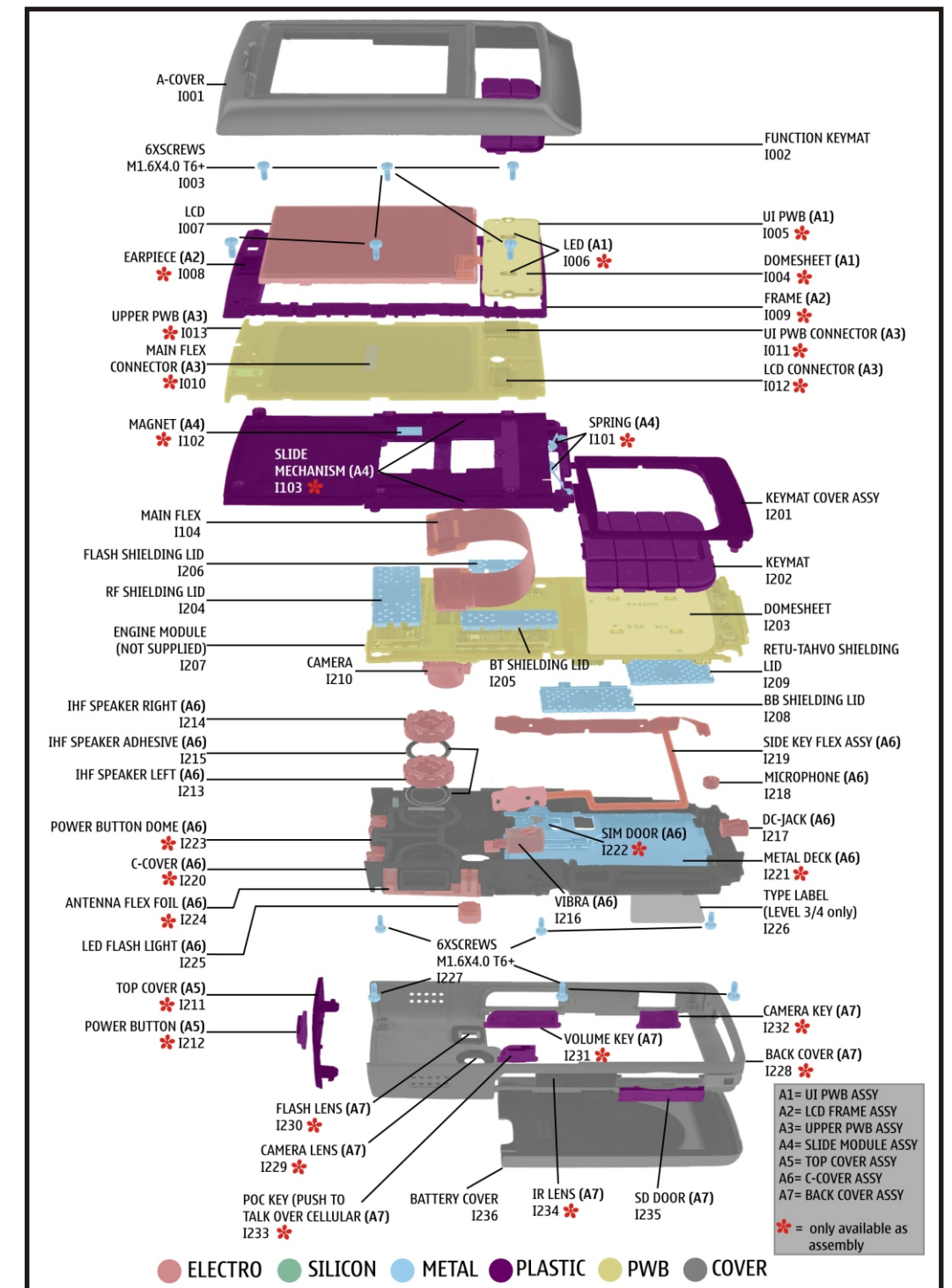
This material, including documentation and any related computer programs is protected by copyright, controlled by NOKIA. All rights are reserved. Copying, including reproducing, modifying, storing, adapting or translating any or all of this material requires the prior written consent of NOKIA. This material also contains company confidential information, which may not be disclosed to others without the prior written consent of NOKIA.

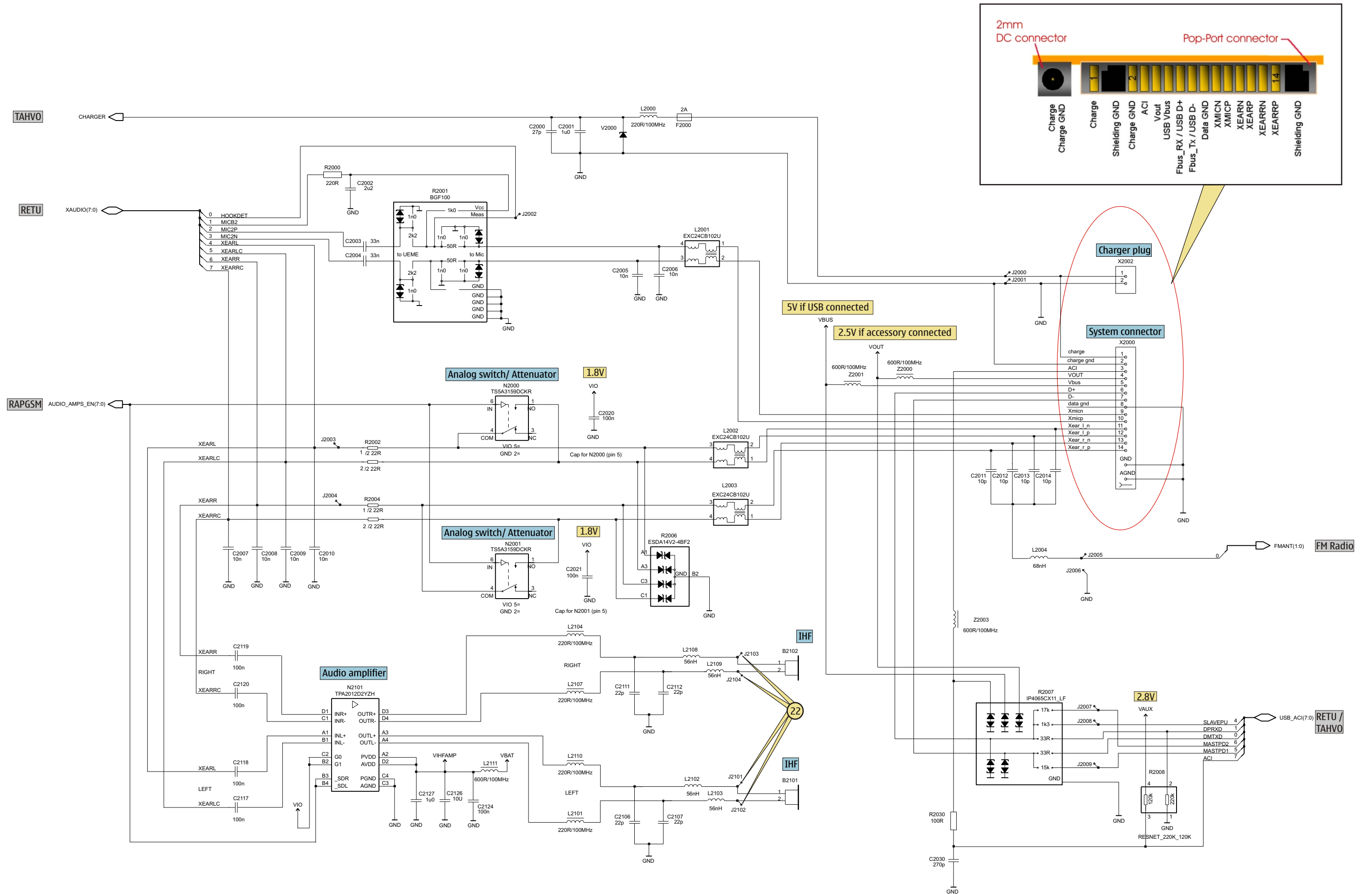
## RM-56

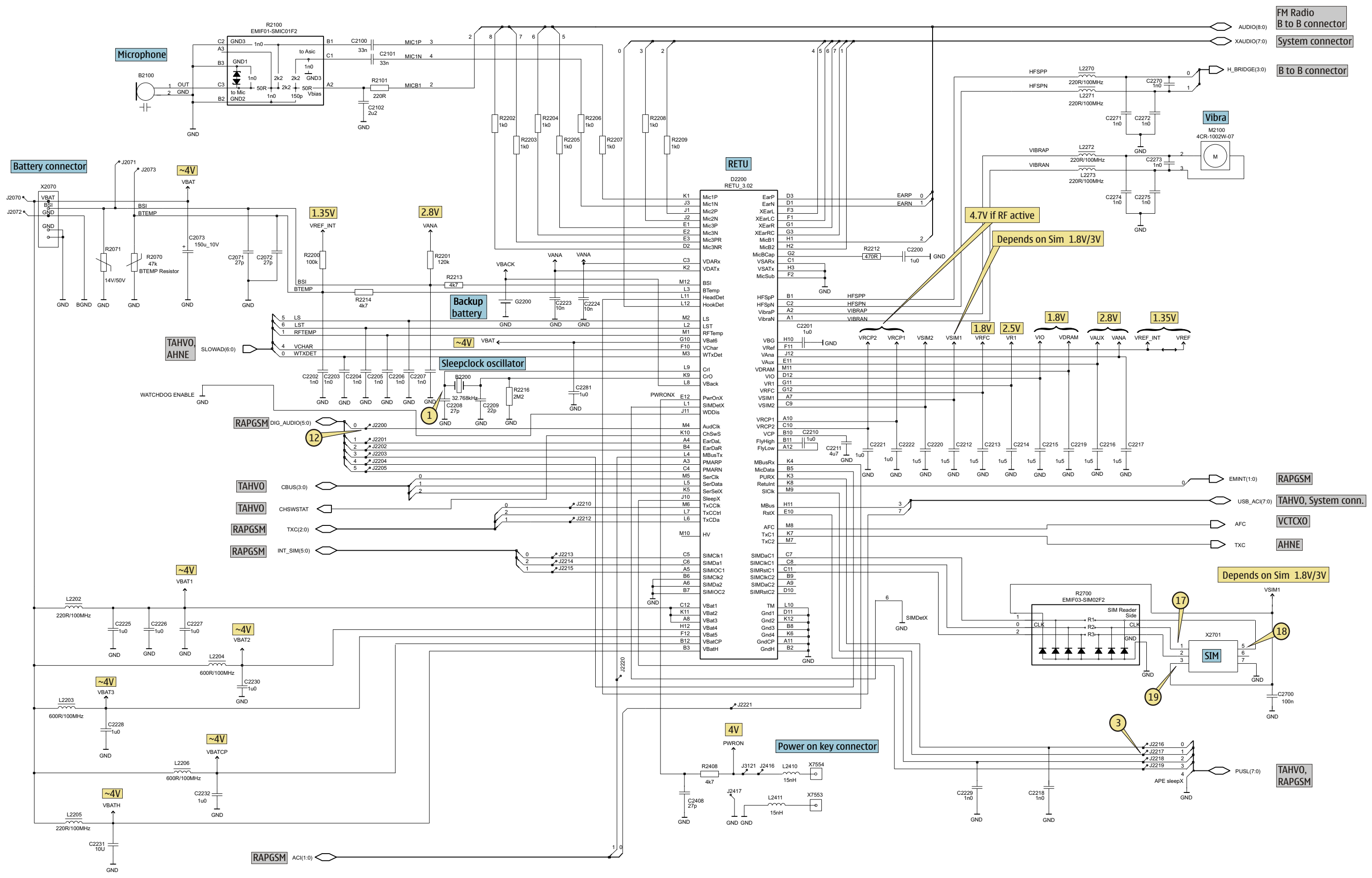


Table of Contents	Page
Front page	1
Audio	2
RETU	3
TAHVO	4
RAPGSM, Combo memory, Camera	5
UI	6
BT, FM radio	7
RF part	8
Signal overview	9
Component finder	10

## Exploded view and component disposal







FM Radio  
B to B connector

System connector

B to B connector

RAPGSM

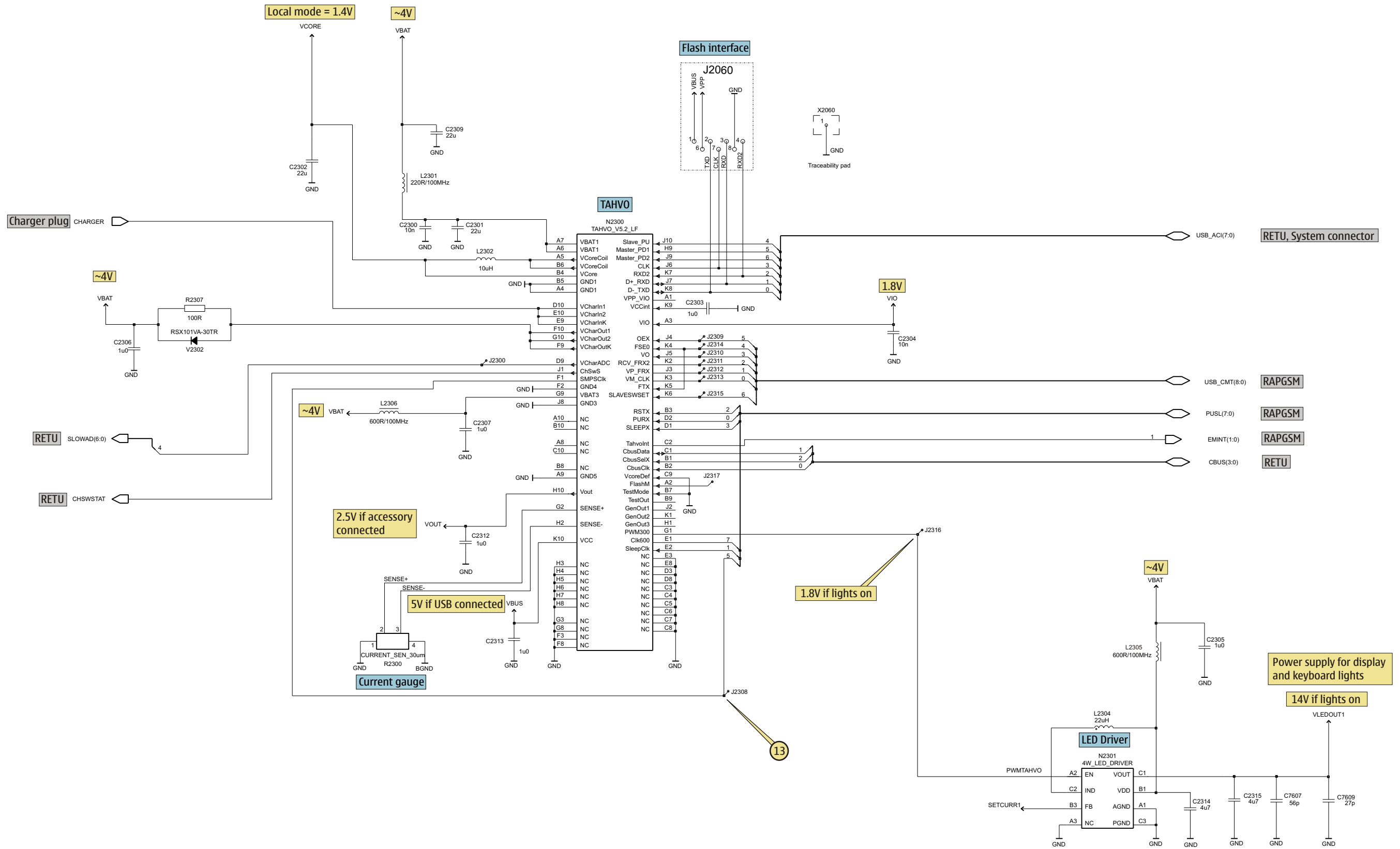
TAHVO, System conn.

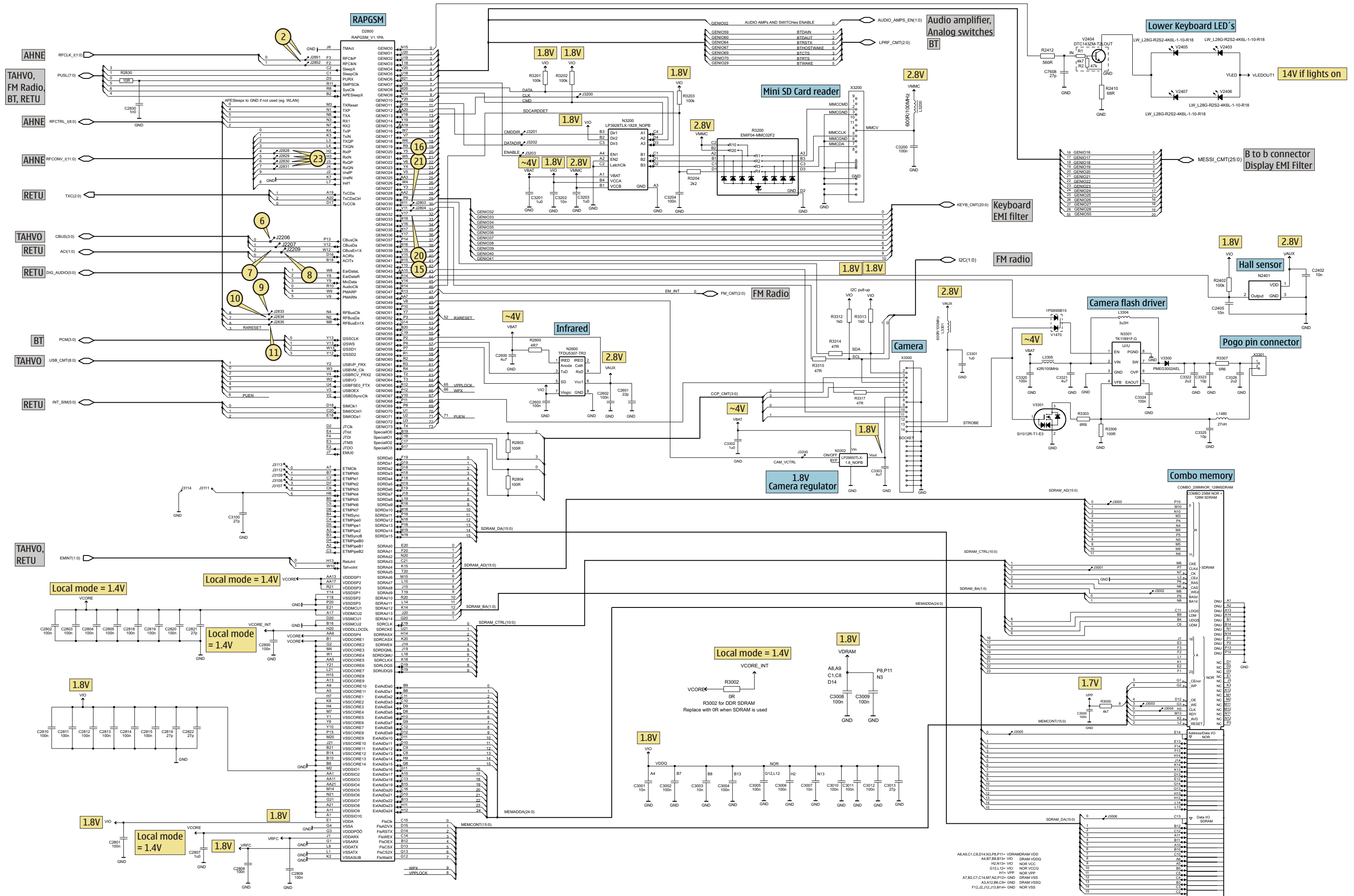
VCTCX0

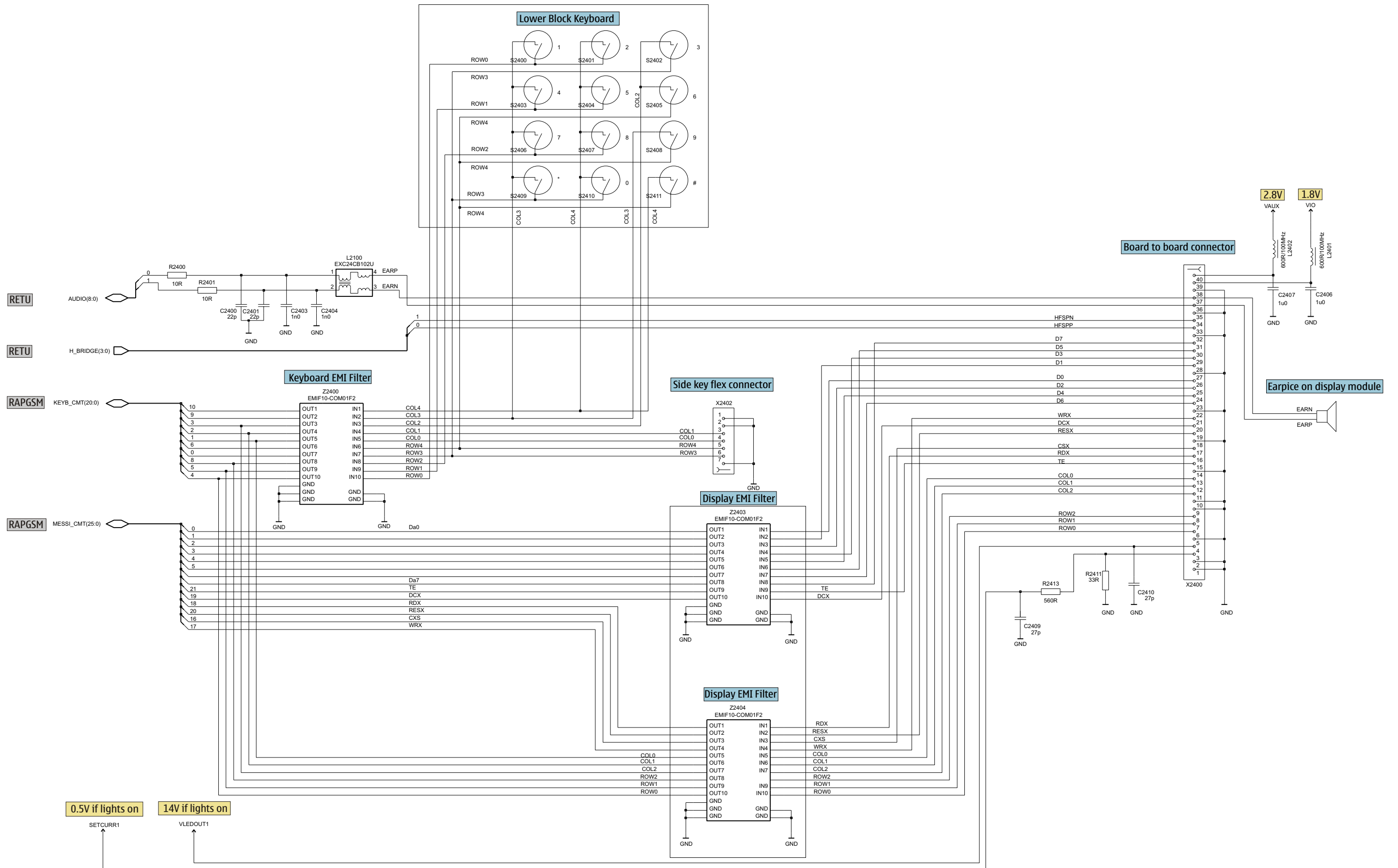
AHNE

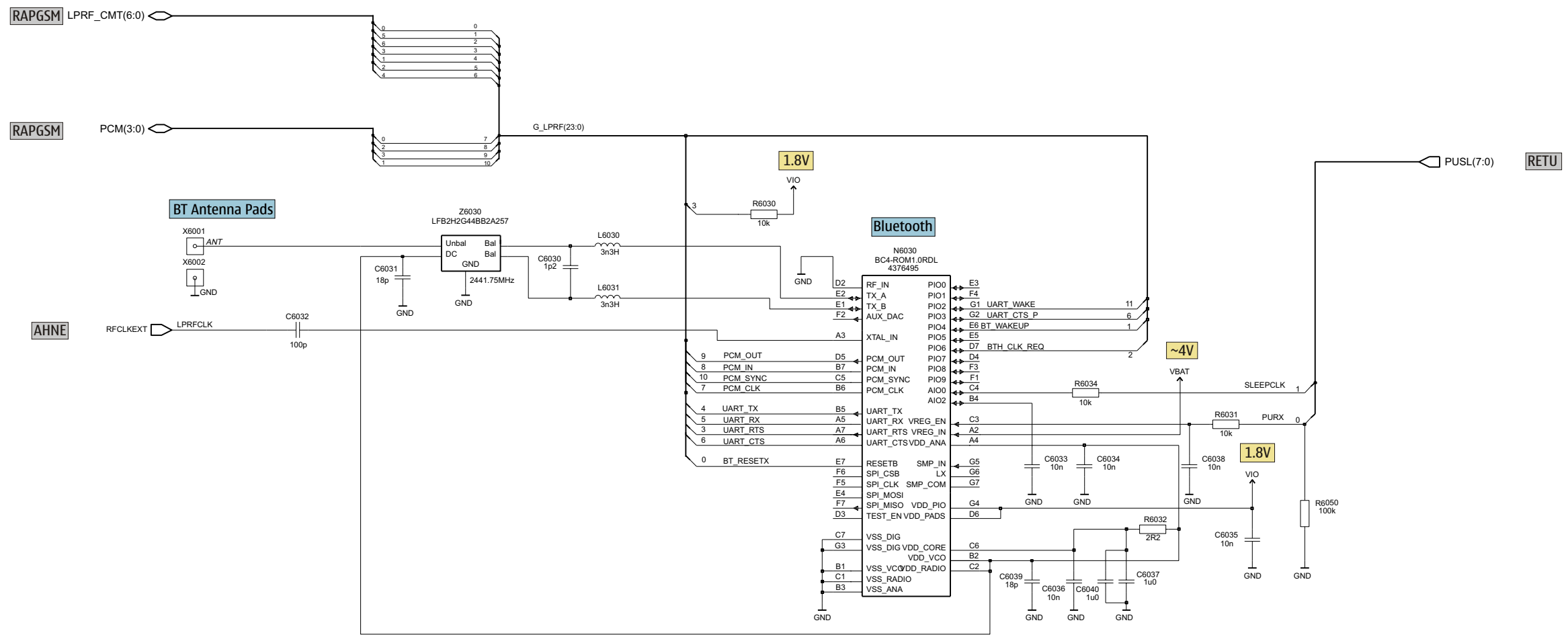
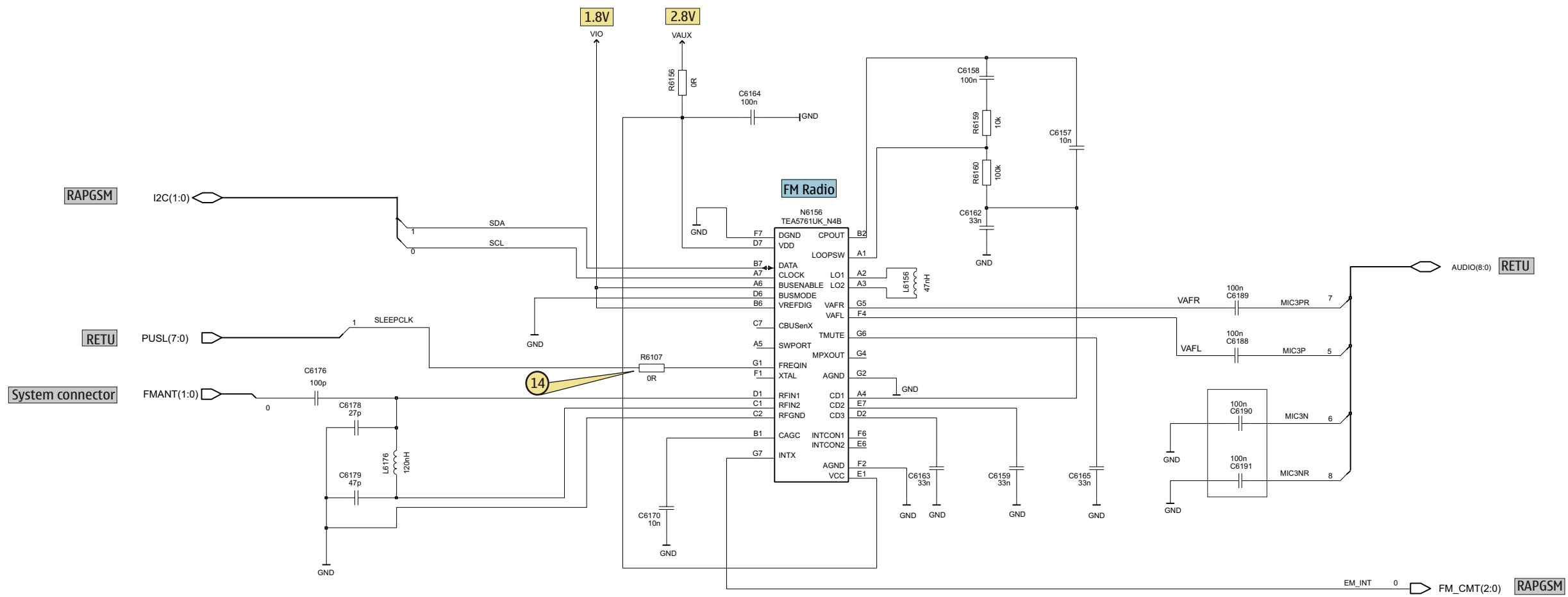
Depends on Sim 1.8V/3V

TAHVO, RAPGSM



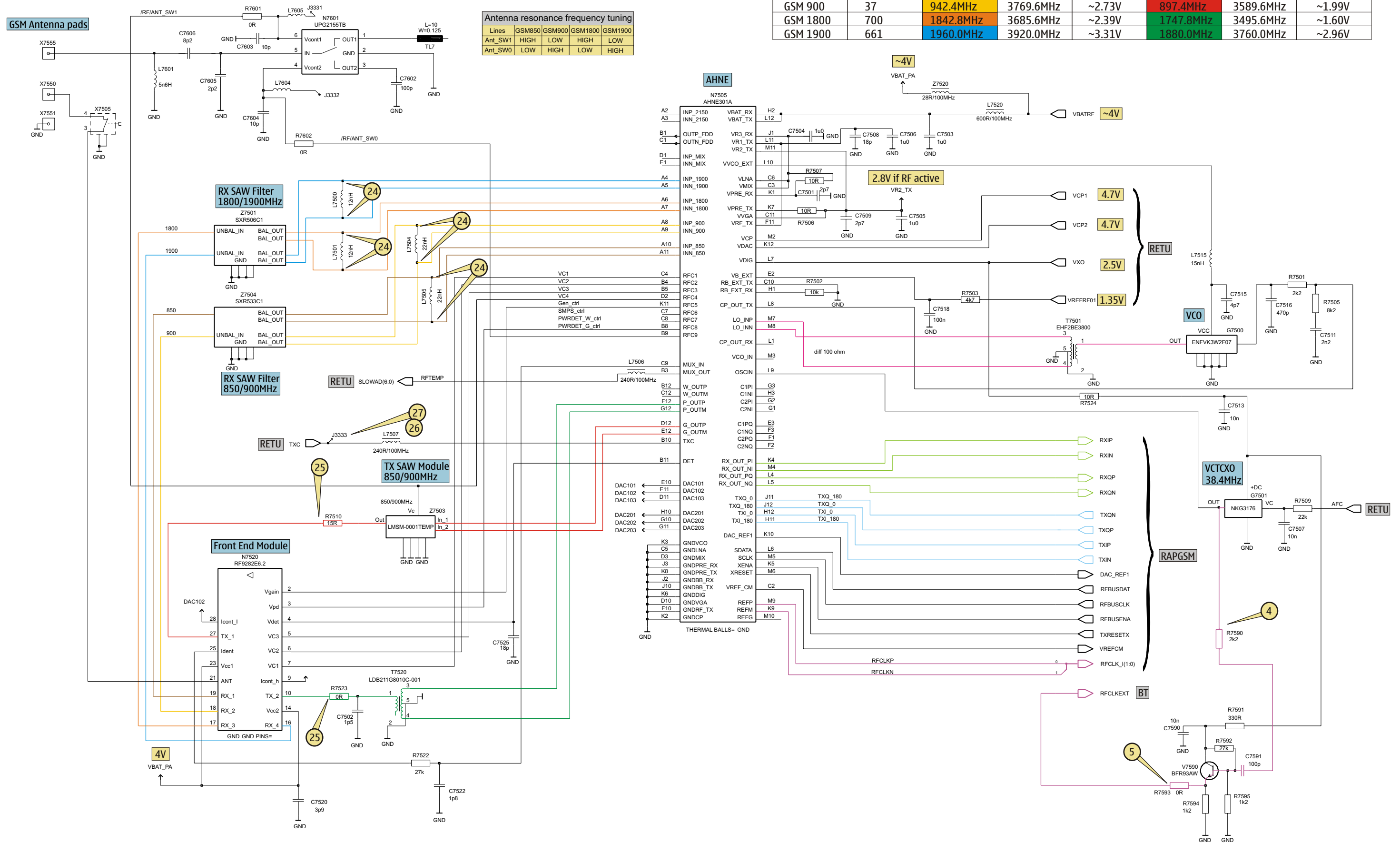




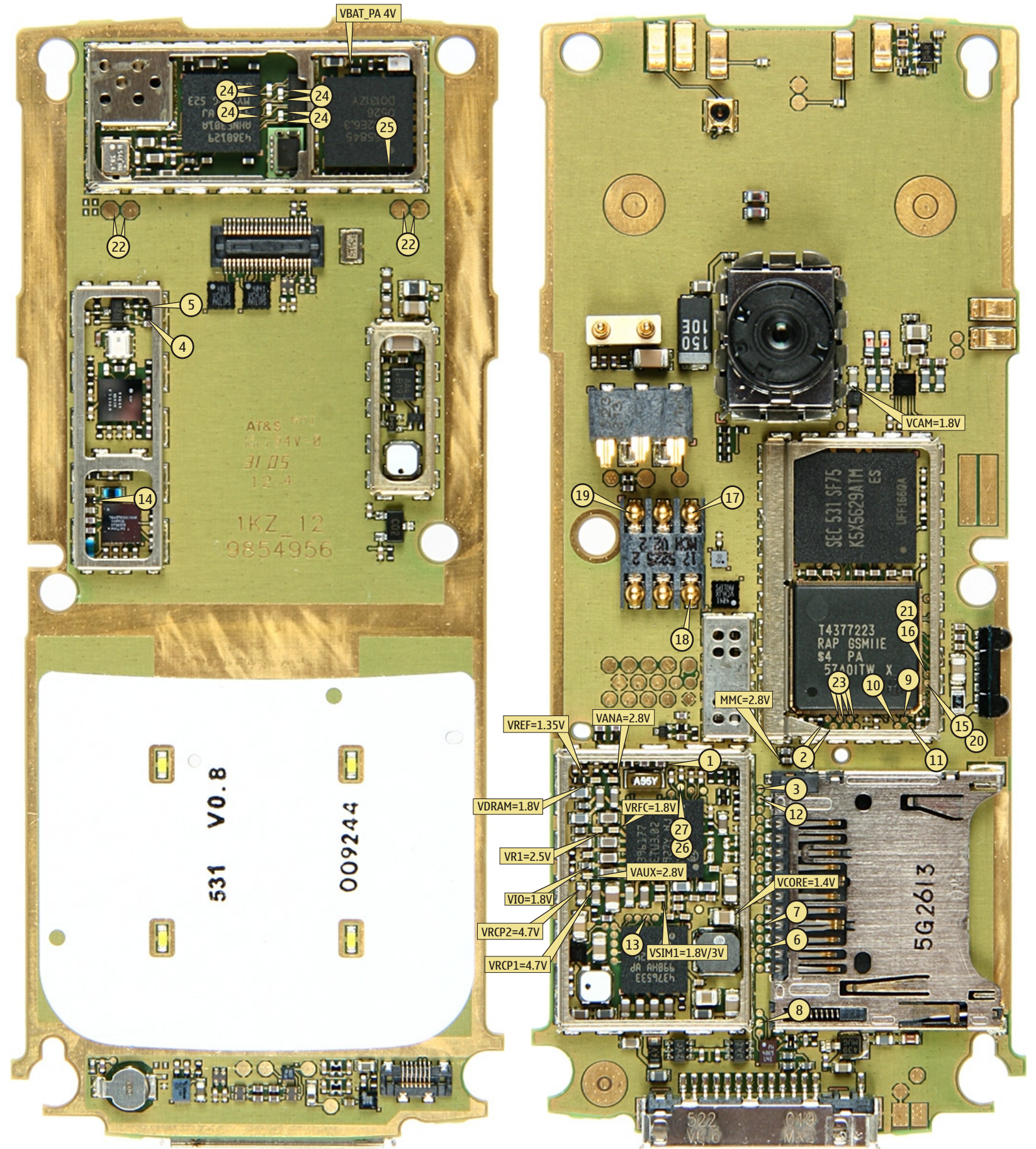
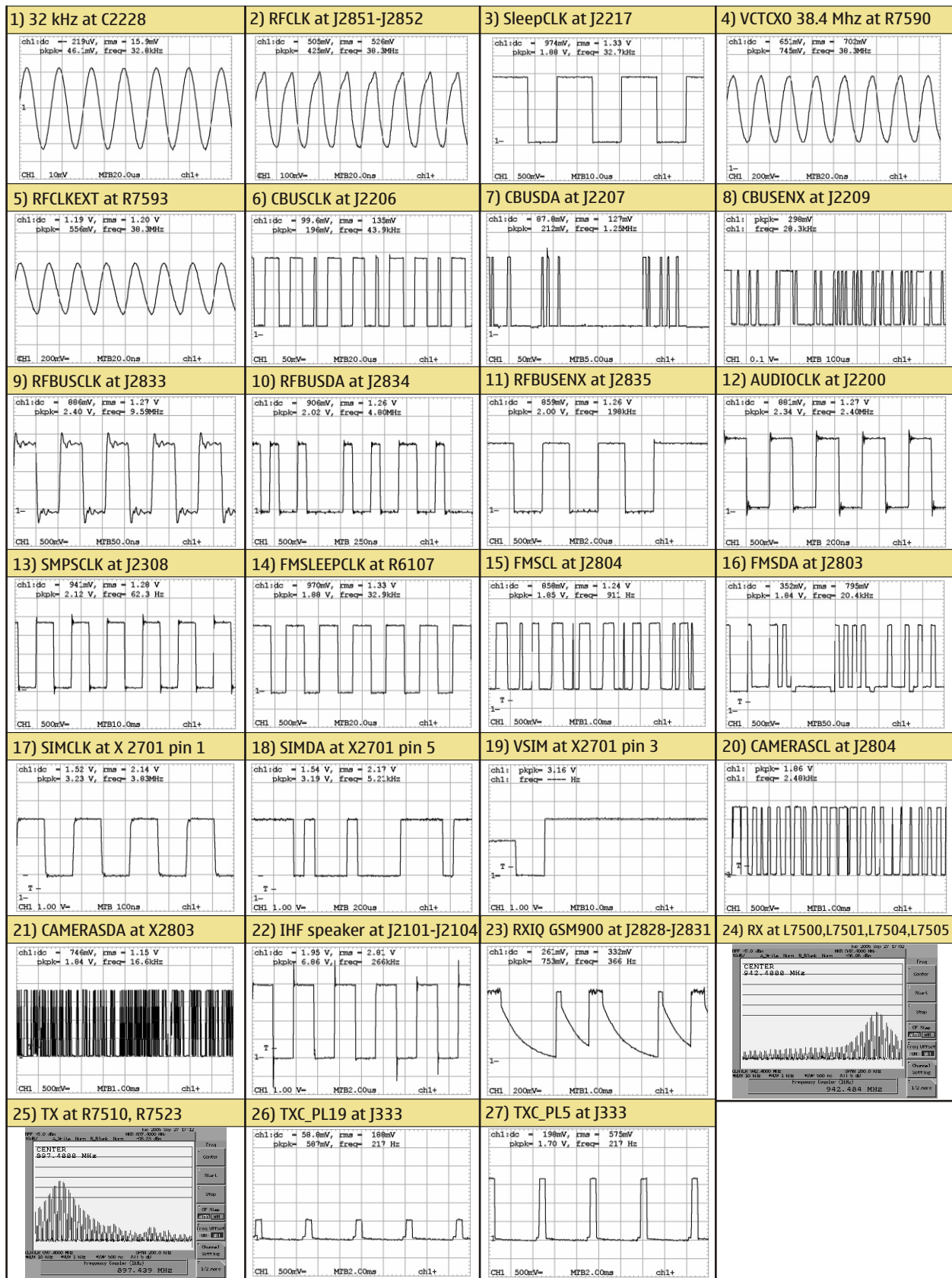


Band	Channel	RX	VCO/RX	VC/RX	TX	VCO/TX	VC/TX
GSM 850	190	881.6MHz	3526.4MHz	~1.8V	836.6MHz	3346.4MHz	~1.5V
GSM 900	37	942.4MHz	3769.6MHz	~2.73V	897.4MHz	3589.6MHz	~1.99V
GSM 1800	700	1842.8MHz	3685.6MHz	~2.39V	1747.8MHz	3495.6MHz	~1.60V
GSM 1900	661	1960.0MHz	3920.0MHz	~3.31V	1880.0MHz	3760.0MHz	~2.96V

Lines	GSM850	GSM900	GSM1800	GSM1900
Ant_SW1	HIGH	LOW	HIGH	LOW
Ant_SW0	LOW	HIGH	LOW	HIGH







B	C2222	P8	C2819	K4	C7502	A7	J2205	O7	J3332	G2	N3200	L6	R3313	I6	X7551	A7		
B2200	N7	C2223	P6	C2820	M3	C7503	C3	J2206	Q5	J3333	O7	N3301	G8	R3314	H6	X7553	A6	
C	C2224	O6	C2830	M4	C7504	A4	J2207	Q5	L	N3302	G4	R3315	H6	X7554	A4	Z		
C2000	S4	C2225	O8	C3000	I2	C7505	C3	J2209	Q5	L1480	G8	N6030	G3	R3317	H6	X7555	A3	
C2001	T4	C2226	P8	C3001	I2	C7506	C3	J2210	O7	L2000	S3	N6156	J3	R6030	H3	Z	Z2000	T5
C2002	T4	C2227	P7	C3002	I2	C7507	C3	J2212	O5	L2001	T4	N7505	B4	R6031	G2	Z2000	T5	
C2003	T4	C2228	P8	C3003	J5	C7508	C3	J2213	P5	L2002	T5	N7520	B7	R6032	H2	Z2001	T5	
C2004	T4	C2229	Q7	C3004	J5	C7509	C3	J2214	P5	L2003	T6	N7601	A2	R6034	G3	Z2003	S5	
C2005	T4	C2230	O8	C3005	I5	C7511	B3	J2215	Q5	L2004	T6	R	R6050	G2	Z2400	K6		
C2006	T4	C2231	P6	C3006	I5	C7513	C3	J2216	R5	L2100	E6	R2000	T4	R6107	I2	Z2403	F5	
C2007	T7	C2232	P8	C3007	I5	C7515	A3	J2217	O5	L2101	G3	R2001	T4	R6156	I3	Z2404	F4	
C2008	T6	C2273	Q7	C3008	J5	C7516	B3	J2218	R5	L2102	F3	R2002	T6	R6159	I2	Z6030	F3	
C2009	T6	C2274	Q7	C3009	I5	C7518	C4	J2219	Q5	L2103	F3	R2004	T6	R6160	I2	Z7501	B6	
C2010	T7	C2275	Q6	C3010	M2	C7520	B7	J2220	O5	L2104	G2	R2006	T6	R7501	B3	Z7503	C6	
C2011	T5	C2281	P9	C3011	K4	C7522	C7	J2221	O5	L2107	G2	R2007	S5	R7502	A4	Z7504	B6	
C2012	T5	C2300	R6	C3012	K3	C7525	C8	J2300	Q7	L2108	D5	R2008	S5	R7503	C4	Z7520	A6	
C2013	T5	C2301	R6	C3013	K4	C7590	F2	J2308	Q7	L2109	D5	R2030	S4	R7505	B3			
C2014	T5	C2302	Q6	C3100	M7	C7591	F3	J2309	Q8	L2110	G3	R2070	T2	R7506	C4			
C2020	S6	C2303	O8	C3200	N5	C7602	A2	J2310	Q8	L2111	F3	R2011	I8	R7507	A4			
C2021	S6	C2304	Q7	C3201	L6	C7603	B2	J2311	Q8	L2202	O9	R2100	T7	R7509	C3			
C2030	S5	C2305	S9	C3202	L6	C7604	A3	J2312	Q8	L2203	O9	R2101	T7	R7510	C7			
C2071	I8	C2306	S8	C3203	M6	C7606	A3	J2313	Q8	L2204	O9	R2200	N9	R7522	C7			
C2072	T2	C2307	S7	C3204	M6	C7607	R9	J2314	Q8	L2205	O9	R2201	N8	R7523	A7			
C2073	F7	C2309	R6	C3301	E6	C7608	N7	J2315	R8	L2206	P8	R2202	O6	R7524	C4			
C2100	T7	C2312	S7	C3302	H4	C7609	R9	J2316	Q8	L2272	P7	R2203	O6	R7590	F3			
C2101	T7	C2313	S8	C3303	G4	D	J2317	Q6	L2273	P6	R2204	O6	R7591	F2				
C2102	S7	C2314	Q8	C3320	F8	D2200	O7	J2416	B5	L2301	S6	R2205	O6	R7592	F2			
C2106	G3	C2315	Q9	C3321	F8	D2800	L4	J2417	B5	L2302	O6	R2206	N6	R7593	F3			
C2107	G3	C2400	M8	C3322	F8	D3000	I4	J2803	L2	L2304	R8	R2207	N6	R7594	F3			
C2111	G2	C2401	M8	C3323	G8	F	J2804	M2	L2305	S8	R2208	N6	R7601	B3				
C2112	G2	C2402	I7	C3324	G8	F2000	S3	J2828	M4	L2306	T7	R2209	N6	R7602	A3			
C2117	H3	C2403	F6	C3325	G8	G	J2829	M4	L2401	E6	R2212	O6	T					
C2118	H3	C2404	F5	C3326	G7	G2200	T3	J2830	M4	L2402	E6	R2213	N8	T7501	B2			
C2119	H2	C2405	J7	C6030	G3	G7500	B3	J2831	M4	L2410	B4	R2214	N9	T7520	A8			
C2120	H3	C2406	F7	C6031	F2	G7501	C2	J2833	M3	L2411	A5	R2216	N8	V				
C2124	G3	C2407	E7	C6032	H3	J	J2834	M3	L3200	N5	R2307	R7	V1470	H8				
C2126	F3	C2408	P9	C6033	H3	J2000	T2	J2835	M3	L3301	E6	R2400	N8	V2000	S4			
C2127	G3	C2409	Q8	C6034	G3	J2001	T3	J2851	M4	L3304	I8	R2401	N8	V2302	S7			
C2200	O6	C2410	D6	C6035	H2	J2002	O5	J2852	M4	L3305	E8	R2402	J7	V2403	Q7			
C2201	O8	C2600	L2	C6036	H3	J2007	S5	J3000	H4	L6030	G3	R2408	P9	V2404	N7			
C2202	N9	C2601	L2	C6037	H3	J2008	S5	J3001	H4	L6031	G2	R2410	M7	V2405	N7			
C2203	N7	C2602	L2	C6038	G2	J2009	S5	J3002	K2	L6156	I2	R2411	D6	V2406	Q3			
C2204	N7	C2603	L2	C6039	G3	J2003	T5	J3003	H3	L6176	J2	R2412	N7	V2407	N3			
C2205	N6	C2700	J6	C6040	H2	J2004	T6	J3004	J5	L7500	B5	R2413	Q8	V3300	G8			
C2206	N7	C2800	L5	C6157	I3	J2005	T6	J3005	J5	L7501	B5	R2600	M2	V3301	H7			
C2207	N8	C2801	M5	C6158	I3	J2006	T5	J3006	J4	L7502	C4	R2700	J6	V7590	F2			
C2208	N7	C2802	L5	C6159	J3	J2060	M8	J3107	L8	L7504	B5	R2803	K5	X				
C2209	N7	C2803	K5	C6162	I2	J2070	I8	J3108	L7	L7505	B5	R2804	K5	X2000	T5			
C2210	P8	C2804	M5	C6163	I2	J2071	I7	J3109	L7	L7506	A5	R2830	M4	X2060	E7			
C2211	Q8	C2805	J2	C6164	J3	J2072	I7	J3111	M7	L7507	C5	R3000	J2	X2070	H7			
C2212	Q7	C2807	M5	C6165	J3	J2073	S2	J3112	L7	L7515	B3	R3002	L5	X2400	E5			
C2213	O8	C2808	M5	C6170	I2	J2101	D2	J3113	L8	L7601	A3	R3200	M6	X2402	T8			
C2214	O8	C2809	M5	C6176	J2	J2102	D3	J3114	M7	N	R3201	L6	X2701	J7				
C2215	P8	C2810	K5	C6178	J2	J2103	D8	J3121	M7	N2000	S7	R3202	L6	X3200	Q3			
C2216	P8	C2811	K3	C6179	J2	J2104	D8	J3200	L6	N2001	S6	R3203	M6	X3300	F5			
C2217	N8	C2812	L5	C6188	J2	J2200	O5	J3201	L6	N2101	G3	R3204	M6	X3301	F8			
C2218	Q7	C2813	M2	C6189	J3	J2201	P5	J3202	L6	N2300	R7	R3303	H7	X6001	F1			
C2219	N8	C2814	M5	C6190	N6	J2202	P5	J3203	L6	N2301	R9	R3306	G7	X6002	F1			
C2220	P7	C2815	K5	C6191	N6	J2203	P5	J3330	H4	N2401	J7	R3307	G8	X7505	B6			
C2221	P9	C2818	K3	C7501	A4	J2204	O6	J3331	F2	N2600	L1	R3312	H6	X7550	A7			

